



MOISTURE METERS

SADP Portable Dewpoint Meter

The world renowned SADP portable dewpoint meter from Shaw Moisture Meters offers an easy to use hygrometer for fast and reliable trace moisture measurement.

Designed to operate at atmospheric pressure, the SADP features a large, easy to read analogue indicator scaled in °C dewpoint, °F dewpoint and corresponding parts per million (ppm(V)) range. The TR versions of the SHAW SADP offer the 0 - 10 ppm(V) range expanded over the full scale, which is selected by means of the rotary switch on the front panel. This allows for accurate measurement below 10 ppm(V).

The key to the SHAW automatic dewpoint meter is the unique desiccant head and sensor assembly which allows the sensor to be kept dry between tests. This ensures that the instrument is always available for rapid spot checks of moisture in gases and compressed air.

The SADP portable dewpoint meter is fully self contained and certified intrinsically safe for use in hazardous areas to ATEX and IECEx standards, without the need for any additional accessories such as a Zener barrier or signal isolator. It is also CE and UKCA approved.

The dewpoint meter is supplied, ready for use, with batteries installed, a Certificate of Calibration traceable to National and International Humidity Standards at NPL, two metres of PTFE sampling hose, instruction manual, pressure calculator, screwdriver and a specially designed heavy duty leather case with shoulder strap.



Features

- Guaranteed accuracy $\pm 3\text{ }^{\circ}\text{C}$ to $\pm 4\text{ }^{\circ}\text{C}$ ($\pm 5.4\text{ }^{\circ}\text{F}$ to $\pm 7.2\text{ }^{\circ}\text{F}$) dewpoint
- Intrinsically safe to ATEX and IECEx standards with CE and UKCA approvals
- Various ranges: overall range $-100\text{ }^{\circ}\text{C}$ to $+20\text{ }^{\circ}\text{C}$ ($-148\text{ }^{\circ}\text{F}$ to $+68\text{ }^{\circ}\text{F}$) dewpoint
- Extended range for 0-10 ppm (TR version only)
- Desiccant dry-down chamber assembly for instantaneous readings
- AutoCal (automatic calibration) feature
- Analogue display, indication in $^{\circ}\text{C}$, $^{\circ}\text{F}$ and ppm(V)
- Standard "C" type battery operation
- Self-contained, robust and reliable
- Fully portable
- Simple to operate
- Over 150 hours continuous operation
- Supplied with a Certificate of Calibration traceable to National and International Humidity Standards



MOISTURE METERS

Desiccant Dry-Down Technology

The unique design allows purging of the gas in the "dry-down position" which will bring all surfaces and voids to equilibrium. The "head" can then be raised to take a reading.

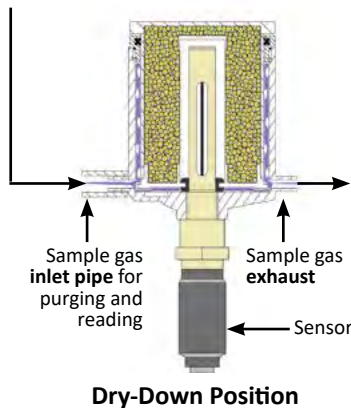

Dry-Down Position

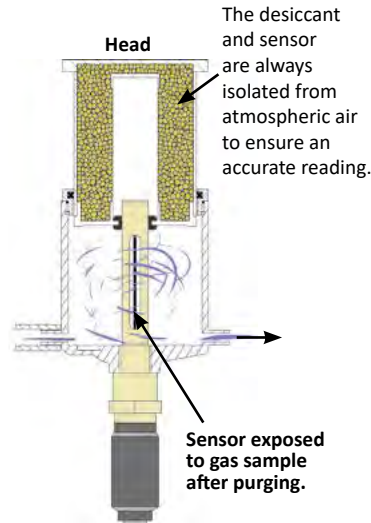

Read Position

The Desiccant Head Assembly

Keeping the sensor dry between tests ensures that the SADP is always ready to carry out rapid spot checks. The unique design of the *desiccant head* achieves this by surrounding the sensor with desiccant before the head is lifted for sampling.

At no time is the sensor allowed to come into contact with ambient air. The chamber is also designed so that the void space and chamber wall surfaces are purged with sample gas, prior to exposure of the sensor, giving faster, more accurate and reliable results.

Automatic Calibration

The most important and unique feature of the SHAW system is the **automatic calibration** facility. Each SHAW sensor is precisely manufactured to saturate with water vapour at its design maximum. Hence, when the sensor is exposed to moisture above its maximum operating range, it will rapidly come into equilibrium and cease to respond to any further increase in moisture. This forms the basis of AutoCal (automatic calibration).

The SHAW sensor can be checked by simply exposing it to any atmosphere which is wetter than the operating range of the sensor (usually room air is sufficient) and adjusting the calibration control on the front panel of the instrument. The sensor is now set up with the instrument and ready for use.

AutoCal can be carried out in-situ and without the need for any special equipment or skilled personnel. The net result is reduced downtime, minimal calibration costs and immediate verification of the system.



SADP complete with two metres of PTFE sampling hose, pressure calculator, instruction manual and heavy duty leather case with shoulder strap.

Specifications

DEWPOINT SENSOR

- Sensing Element**
 SHAW Ultra High Capacitance Aluminium Oxide Sensor
- Ranges**

P (Purple):	-100 to 0 °C dewpoint	0 - 6,000 ppm(V)
S (Silver):	-100 to -20 °C dewpoint	0 - 1,000 ppm(V)
G (Grey):	-80 to 0 °C dewpoint	0 - 6,000 ppm(V)
R (Red):	-80 to -20 °C dewpoint	0 - 1,000 ppm(V)
B (Blue):	-80 to +20 °C dewpoint	0 - 23,000 ppm(V)
TR-G (TR-GREY):	-80 to 0 °C dewpoint	0 - 6,000 & 0 - 10 ppm(V)
TR-R (TR-RED):	-80 to -20 °C dewpoint	0 - 1,000 & 0 - 10 ppm(V)
- Intrinsic Safety Certification**

 ATEX: Ex II 1 G Ex ia IIC T6 Ga
 IECEx: Ex ia IIC T6 Ga
- Approvals**

 CE 0598 UKCA 1180
- AutoCal**
 Field calibration/span check facility. Activated and operated via potentiometer on the front of the instrument
- Factory Calibration**
 Supplied with Certificate of Calibration traceable to National Physical Laboratory (NPL)
- Accuracy**
 ± 3 °C (± 5.4 °F) dewpoint (Red/Silver)
 ± 4 °C (± 7.2 °F) dewpoint (all others)
 NPL traceable -90 °C to +20 °C (-130 °F to +68 °F)
- Response Times**
 Wet to dry: -20 °C to -60 °C (-4 °F to -76 °F) - less than 120 secs
 Dry to wet: -100 °C to -20 °C (-148 °F to -4 °F) - less than 20 secs
- Sample Flow Rate**
 Flow independent but ideally 2 to 5 litres per minute
 Max: 20 litres per minute
- Calibration Warranty** 12 months from date of dispatch

ELECTRICAL

- Electromagnetic Compatibility (EMC)**
 Immunity: complies with EN 61000-6-1
 Emissions: complies with EN 61000-6-3
- Warm Up Time**
 5 seconds
- Display**
 Analogue: 120 mm Taut Band indicating meter showing dewpoint and ppm with amplified range of 0 - 10 ppm on TR versions.
- Power Supply**
 9 V DC – six “C” type batteries (included)
- Battery Life**
 In excess of 150 hours continuous operation
- Resolution**
 0.1 °C, 0.2 °F dewpoint or 0.1 ppm(V)
- Repeatability**
 Better than ±0.5 °C (±0.9 °F) dewpoint

MECHANICAL

- Dimensions and Weight**
 Overall dimensions: 200 mm (w) x 225 mm (d) x 278 mm (h) Height (328 mm with head extended) Weight 4.5 kg
- Operating Pressure**
 Atmospheric to 0.3 barg
- Operating Humidity (External)**
 Maximum - 95% RH non-condensing
- | | |
|-------------------------------------|-------------------------------------|
| Operating Temperature | Storage Temperature |
| -20 °C to +50 °C (-4 °F to +122 °F) | -20 °C to +40 °C (-4 °F to +104 °F) |
- Sensor Protection**
 316 sintered stainless steel filter - 50 micron
- Weatherproof Classification**
 IP66/NEMA 4X
- Connections**
 Two Fir Tree type on either side of desiccant chamber
- Mechanical Warranty**
 24 months in case of faulty workmanship and defective parts

Guide to Installation

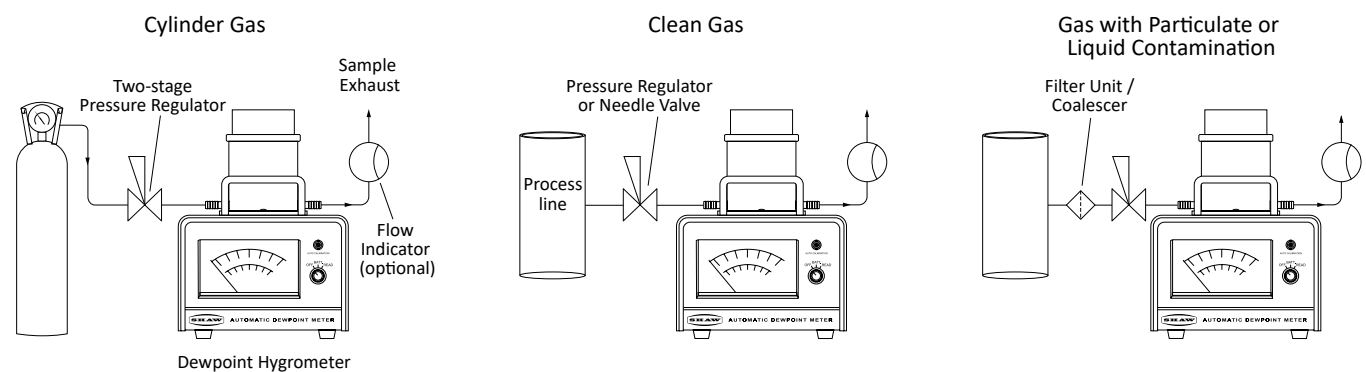

Ordering Information

SADP



SADP - (R)

(R) - Choose required range:

P (Purple):	-100 to 0 °C dewpoint	0 - 6,000 ppm(V)
S (Silver):	-100 to -20 °C dewpoint	0 - 1,000 ppm(V)
G (Grey):	-80 to 0 °C dewpoint	0 - 6,000 ppm(V)
R (Red):	-80 to -20 °C dewpoint	0 - 1,000 ppm(V)
B (Blue):	-80 to +20 °C dewpoint	0 - 23,000 ppm(V)
TR-G (TR - GREY):	-80 to 0 °C dewpoint	0 - 6,000 & 0 - 10 ppm(V)
TR-R (TR - RED):	-80 to -20 °C dewpoint	0 - 1,000 & 0 - 10 ppm(V)

Example:

To order a SADP with a measuring range of -80 to 0 °C dewpoint (grey sensor) please order as **SADP-G**

SADP General Assembly Diagram

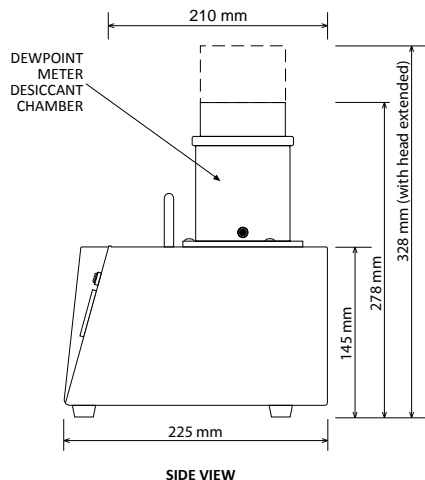
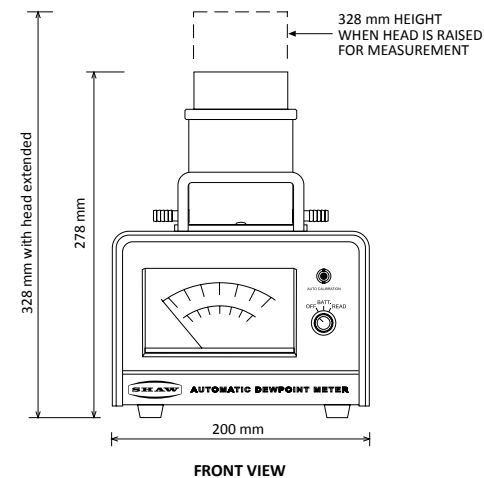

Related Products

SU3 Sample Plate

Attaches to the side of the SADP case.

Comprises a flow meter, filter unit, pressure regulator (210 bar) and pressure gauge.



SU2 Sample Plate

Mounts on top of the SADP. Comprises a

flow meter, pressure regulator (210 bar) and pressure gauge.



Pressure Regulator

For accurate control of pressure at all important points in a sample system.



Flow Meter

Compact flow meter provides visual indication and fine control of sample flow.



Service Kit

Includes desiccant, head seal kit, grommet, silicone grease and batteries.

Includes as standard:

Dewpoint sensor, batteries (installed), Certificate of Calibration, two metres PTFE sampling hose, screwdriver, Allen key, pressure calculator, instruction manual and leather carry case.