

Model SDT-Ex

Dewpoint Transmitter

Instruction Manual

Issue 1.2.1



EU Declaration of Conformity

We Shaw Moisture Meters
Of Len Shaw Building, Bolton Lane, Bradford, England, BD2 1AF

Declare that

Model Name: SDT-Ex Intrinsically Safe 4-20 mA Dewpoint Transmitter
Ex II 1 GD
Ex ia IIC T4 Ga (-20 °C ≤ Ta ≤ +60 °C)
Ex ia IIIC T₂₀₀135°C Da (-20 °C ≤ Ta ≤ +60 °C)

Description: The SDT-Ex is an intrinsically safe 3 wire 4-20 mA loop powered transmitter

Conforms to the following directives:

2014/34/EU ATEX Directive

2014/30/EU The Electromagnetic Compatibility Directive

And designed and manufactured to the following standards:

EN IEC 60079-0:2018 Electrical apparatus for potentially explosive atmospheres - General requirements

EN 60079-11:2012 Electrical apparatus for potentially explosive atmospheres - Intrinsic safety 'i'

I hereby declare that the above-mentioned equipment complies with the relevant sections of the above referenced specifications.

This declaration of conformity is issued under the sole responsibility of the manufacturer.



Andrew Coulton
Calibration & QA Manager

13th October 2023

ATEX CERTIFICATE NUMBER: Baseefa07ATEX0235 Issue 3

IECEx CERTIFICATE NUMBER: IECEx BAS 07.0081 Issue 4

Notified Body for ATEX & IECEx:

SGS Fimko Oy, Takomotie 8, FL-00380 Helsinki, Finland

Notified Body No. 0598

CP12A issue 12

UK Declaration of Conformity

We Shaw Moisture Meters
Of Len Shaw Building, Bolton Lane, Bradford, England, BD2 1AF

Declare that

Model Name: SDT-Ex Intrinsically Safe 4-20 mA Dewpoint Transmitter
Ex II 1 GD
Ex ia IIC T4 Ga (-20 °C ≤ Ta ≤ +60 °C)
Ex ia IIIC T₂₀₀135°C Da (-20 °C ≤ Ta ≤ +60 °C)

Description: The SDT-Ex is an intrinsically safe 3 wire 4-20 mA loop powered transmitter

Conforms to the following directives:

Equipment and Protective Systems Intended for use in Potentially Explosive Atmospheres Regulations 2016:1107
Electromagnetic Compatibility Regulations 2016:1091

And designed and manufactured to the following standards:

EN IEC 60079-0:2018 Electrical apparatus for potentially explosive atmospheres - General requirements
EN 60079-11:2012 Electrical apparatus for potentially explosive atmospheres - Intrinsic safety 'i'

I hereby declare that the above-mentioned equipment complies with the relevant sections of the above referenced specifications.

This declaration of conformity is issued under the sole responsibility of the manufacturer.



Andrew Coulton
Calibration & QA Manager

19th January 2023

UKCA Ex CERTIFICATE NUMBER: BAS21UKEX0655 Issue 1

Notified Body for UKCA:

**SGS Baseefa Limited, Rockhead Business Park, Staden Lane, Buxton, Derbyshire SK17 9RZ, UK
Notified Body No. 1180**

CP12A issue 11

Contents

1.0	Unpacking your Shaw Moisture Meters Model SDT-Ex	5
1.1	General Description	5
2.0	Gas Compatibilities	6
2.1	Installing the SDT-Ex in an Air/Gas Sampling System	6
2.2	Piping Installation Schematic	7
2.3	Piping Schematic Component Index	8
2.4	Installing and Commissioning the Model SDT-Ex Transmitter	9
2.5	Wiring the SDT-Ex	9
2.6	Connector Pins	9
3.0	Normal Operation	10
3.1	Analogue 4 - 20 mA Mode (3 Wire)	10
4.0	AutoCal	10
4.1	Pre-conditioning the Transmitter	11
4.2	Adjust the AutoCal	11
4.3	Completing the AutoCal	12
4.4	Faults/Errors	12
5.0	Guarantee	13
6.0	Basic Definitions	14
7.0	SDT-Ex Specification	14
8.0	Hygrometric Equivalents	15
9.0	Appendix	16
9.1	Appendix A - SDT-Ex and PR5104BB2A Signal Isolator Connection	16
9.2	Appendix B - PR5104BB2A to SDT-Ex Connections	17
9.3	Appendix C - SDT-Ex with Connector, General Arrangement	18
9.4	Appendix D - Transmitter Holder General Arrangement	19

1.0 Unpacking your Shaw Moisture Meters Model SDT-Ex

Please examine the SDT-Ex package for any damage or mishandling. If any damage is evident please notify the carrier and the Shaw Moisture Meters representative from where this unit was purchased.

You should have received (if ordered):

- 1 SDT-Ex 4-20 mA dewpoint transmitter
- 1 connecting cable, 2m as standard (or length specified on your order)
- 1 SDT-Ex special sensor holder
- 1 instruction manual
- 1 pressure dewpoint circular calculator

If anything is missing please contact your distributor immediately.

1.1 General Description

The Shaw Moisture Meters SDT-Ex is a 3 wire, 4-20 mA loop powered transmitter, used for continuous measurement of moisture in a process gas or compressed air. The SDT-Ex dewpoint transmitter can be factory configured to output a 4-20 mA linear signal for any of the following moisture units: °C or °F dewpoint, ppm(V), ppb(v), g/m³ and lb/MMSCF.

The ultra high capacitance SHAW sensing element is long lasting and offers excellent sensitivity, repeatability and response speed. Each unit is calibrated, traceable to International Humidity Standards at NPL and supplied with a Certificate of Calibration guaranteeing accuracy to ± 2 °C (± 3.6 °F) dewpoint.

The transmitter also incorporates an automatic calibration feature, known as AutoCal, which allows the user to carry out field calibration/span check. AutoCal is operated by means of a small potentiometer built into the transmitter body. To avoid accidental corruption, the potentiometer is covered by a weatherproof seal in normal use.

The RISC microprocessor circuitry of the SDT-Ex transmitter allows high resolution with advanced self-diagnostics for fault conditions. It also enables periodic recalibration of the moisture sensor, storing calibration data within the fully self-contained unit. Loop powered by a 7 V to 28 V DC source, the SDT-Ex transmitter will provide the user with a linear 4-20 mA signal over the chosen range.

The mechanics of the SDT-Ex transmitter have been designed to cope with extreme environmental conditions. The rugged stainless steel construction and anodised aluminium offers protection to IP66 (NEMA 4X) with the transmitter electrical connections made via secure industrial type connector (size C, DIN EN 175301).

The SDT-Ex transmitter can withstand 35,000 kPa (350 bar) maximum pressure and by employing low resistance cable. The transmitter can be located at significant distances, in excess of 1,000 metres from the data collection point.

Designed with the operator in mind, for reliable and accurate measurements, the SDT-Ex transmitter is extremely easy to install and operate, requiring little or no maintenance.

2.0 Gas Compatibilities

The sensing elements of the SDT-Ex transmitter are Al₂O₃ and therefore suitable for many different industrial and research applications. Most gases can be checked for their moisture content with no need for the calibration to be altered when changing between different gases, as the sensor operates only with reference to the water vapour content.

However, some gases must be avoided as they are not compatible with the material used in construction of the sensor. Ammonia (NH₃) and Chlorine (Cl₂) must be avoided at all times, even in small quantities. Hydrogen Chloride (HCl) also attacks the sensors very quickly. Some less aggressive acidic gases, such as Sulphur Dioxide (SO₂), can be monitored as long as the moisture content is low, generally less than 100 ppm(V). If in doubt, please ask your supplier.

Sulfur hexafluoride (SF₆) has no effect on the sensor. If the gas has been exposed to arcing however, it is possible that various acidic species will have formed that will corrode the sensor. Therefore, when testing SF₆ that may have been arced, an acidity test should be carried out first, if the gas proves to be acidic then the moisture test should not be carried out.

It is strongly recommended that the sample should not contain particulate matter, oil or other heavy hydrocarbon condensate. If these components contaminate the sample system and/or the measuring sensor, the system response time will be lengthened, although the sensor calibration will not be effected.

2.1 Installing the SDT-Ex in an Air/Gas Sampling System

The piping installation schematic diagram shows all components which could be used in a gas measurement application. Not all items shown will be required for every installation.

The flow rate, although not critical, should be low enough to avoid abrasion to the sensor surface without being so low as to extend the system response time to an unacceptable level. In general, a flow rate of between 2-3 litres per minute at normal temperature and pressure will give the right balance. The sensor is a variable capacitor, which is directly affected by changes in partial pressure of water vapour. These changes are proportional to the dew point/frost point temperature.

The measuring transmitter can be installed directly into the process line. Quite often this creates problems with access for maintenance and calibration. It is for these reasons we recommend installing the transmitter in a bypass, fast loop or total loss sample system where the transmitter is accessible without interrupting the main process flow line.

2.2 Piping Installation Schematic

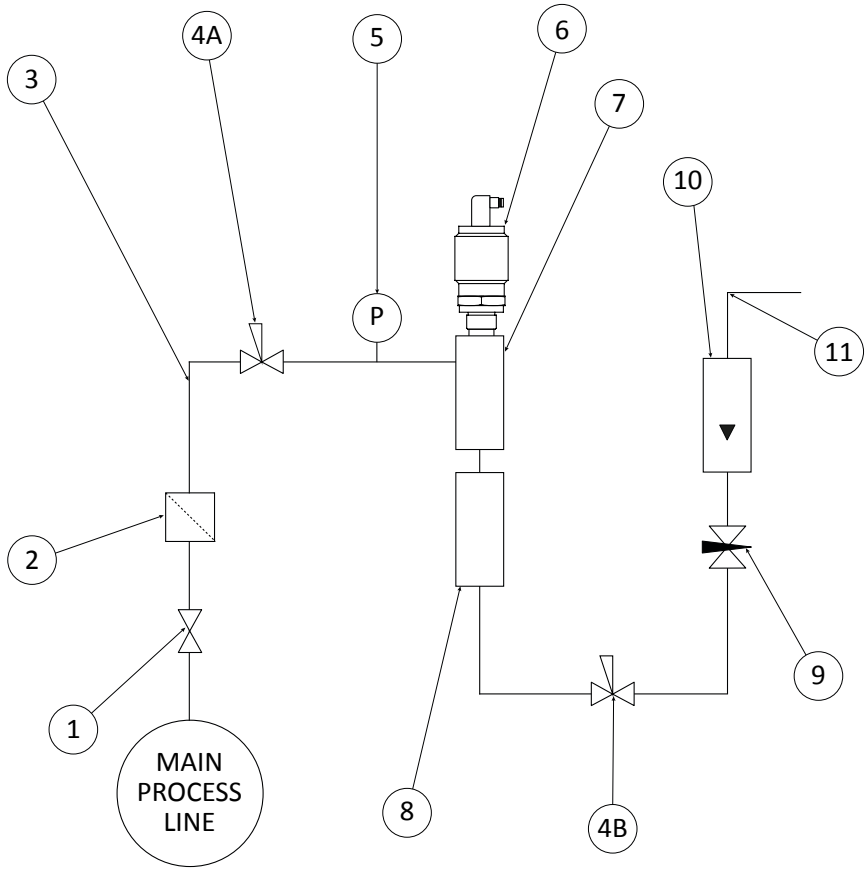

Notes

- a. The sample pipe should be on the upper surface of the horizontal pipe or on a vertical section of pipe wherever possible.
- b. The sample tube should run continually upwards from the sample point. If this is not possible then an inspection port or drain tap should be installed at the lowest point in the system.

2.3 Piping Schematic Component Index

1. **Sample Isolation Valve** - A recommended item as it allows access to the sample system without interrupting the main process line.
2. **Filter Unit** - Recommended when the samples are likely to contain particulate matter. If the air/gas sample contains heavy hydrocarbon condensate, the filter must be of the coalescing type with a drain. The filter unit should be positioned as close to the sample point as practical.
3. **Sample Tube** - This should be stainless steel for dry air or gas applications but copper or carbon steel can be used where wetter gases are to be measured. If any section of the sample tube must be flexible then PTFE should be used. In most cases, 3 mm OD ($\frac{1}{8}$ ") is sufficient as it provides good system response time within minimum flow. 6 mm OD ($\frac{1}{4}$ ") tube can be used where pressure drops across the 3 mm tube are too high.
4. **Pressure Reduction Valve or Pressure Regulator** - If the sample is to be measured at atmospheric pressure then the valve 4A should be fitted and 4B omitted from the system. If the sample is to be measured at full line pressure and the exhaust vented to atmosphere then valve 4B should be fitted and 4A omitted from the system. If measurements are to be taken at full line pressure and the sample is to be returned to a part of the main line or a vent, which is at a pressure higher than atmospheric and the input to that line needs a controlled pressure then both 4A and 4B will be required.
5. **Sample Pressure Gauge** - This is not a critical part of the moisture measurement but may be required if dew point/frost point measurements are to be made at higher than atmospheric pressure.
6. **Transmitter Holder** - see *Appendix B - Transmitter Holder General Arrangement*
7. **Measuring Transmitter** - see *Appendix A - SDT with Connector, General Arrangement*
8. **Desiccant Chamber** - Required when the sampling is to be intermittent. When installed it prevents the ingress of wet air to the sample system, while the sample is not flowing, improving the response time.
9. **Flow Control Valve** - This can be a separate item or combined with the flow indicator.
10. **Flow Indicator** - The recommended sample flow is two to three litres per minute.
11. **Sample Exhaust** - The exhaust can be vented to atmosphere or returned to the process line as discussed above.

2.4 Installing and Commissioning the SDT-Ex Transmitter

It is advisable to carry out an initial purge routine of the sample loop before installing the transmitter in order to remove the possibility of sensor damage on start-up.

Refer to the sample schematic in section 2.2 *Piping Installation Schematic*. Open the inlet isolation valve slowly, until a small flow of air/gas at atmospheric pressure flows through the inlet pipe work to the transmitter holder and exhausts through the sensor entry port of the transmitter holder.

Allow this purge to continue for approximately 15-20 minutes. This is to remove any residual moisture from the sample pipe work and components.

Close the inlet isolation valve and install the transmitter into the transmitter holder. Locate and secure the four-pin transmitter cable connector positioned on the transmitter. Use the locking screw in order to affect a weatherproof seal.

NOTE: The plug and socket will only locate in one position as the GND pin is different to the other three pins.

Open the inlet valve slowly again and by opening all valves after the transmitter holder, allow a low pressure purge through the whole sample system.

Set the required pressures and flows within the sample loop.

This completes the installation and commissioning but on initial start up it could take several hours for the system to reach equilibrium.

2.5 Wiring the SDT-Ex

The SDT-Ex is a 3 wire 4-20 mA transmitter.

For typical electrical connection please see *Appendix A* and *B*.

2.6 Connector Pins

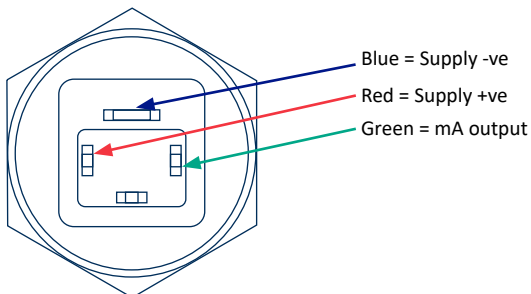

3.0 Normal Operation

3.1 Analogue 4-20 mA Mode (3 Wire)

In normal operation, the transmitter will produce a 4-20 mA signal, which is proportional to the level of moisture in the gas being monitored. The moisture reading is sampled and updated once per second. The SDT-Ex has 3,020 distinct steps over the 4-20 mA range corresponding to a resolution of 0.005 mA.

4.0 AutoCal

AutoCal allows the user to ensure accuracy to the laboratory calibration by checking the span of the transmitter and correcting for any deviation. It should be operated periodically, every two to three months or can be used to verify operation of the SDT-Ex transmitter if confirmation of an unexpected result is required.

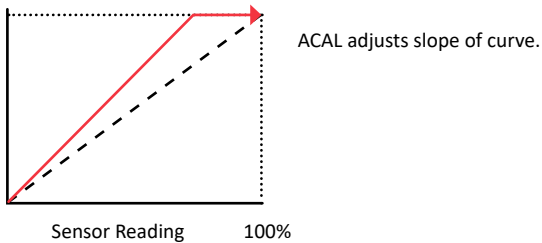

There are two methods of setting the AutoCal.

1. Saturate the transmitter
(Only applicable to °C and °F SDT-Ex transmitters)

If the sensor element is exposed to a dewpoint level above the range of the transmitter, the sensor will saturate and the transmitter output can be set as 20 °C.

The easiest way to achieve this is to wrap ones hand around the sintered stainless steel guard that protects the sensing element.

Note: This is only recommended for transmitters used in non-toxic, non-poisonous, clean gases. Local Health and Safety Procedures should be followed at all times.

2. Expose to a known moisture level
(Applicable to all versions of SDT-Ex transmitters)

If a known gas is available or the ambient dewpoint is known, then the AutoCal can be set to the known value rather than the saturating value.

The SDT-Ex transmitter is supplied with an adjustable potentiometer to perform AutoCal, which allows the calibration span of the transmitter to be adjusted. This potentiometer is located under the weatherproof guard and can be accessed by undoing the large silver coloured screw on the side of the transmitter body. AutoCal is adjusted by turning the potentiometer with the small screwdriver supplied.

The following steps describe the process of setting the AutoCal, describing the two different methods where different.

Note: The SDT-Ex transmitter must be connected to its normal indicator so that readings can be taken or where no indicator is employed, an accurate measurement of the mA output must be taken.

4.1 Pre-conditioning the Transmitter

To perform AutoCal, the transmitter must be removed from the process gas ready to be saturated in the hand or inserted into a known gas flow. At this stage, the display/indicator will read the ambient dewpoint as measured by the SDT-Ex.

Saturating the transmitter method. (Only applicable to °C and °F SDT-Ex transmitters)

Saturate the transmitter by lightly covering the sintered aluminium area with a hand for approximately one minute.

Expose to a known moisture level. (Applicable to all versions of SDT-Ex transmitters)

Expose the transmitter to the known AutoCal moisture level and allow the transmitter to attain equilibrium. (For technical questions and advice on the time taken to attain equilibrium, contact your SDT-Ex transmitter supplier.)

4.2 Adjust the AutoCal

Once the transmitter has been through the pre-conditioning process, the potentiometer can be adjusted. **ONLY ADJUST THE POTENTIOMETER IF THE SENSOR IS PROPERLY PRE-CONDITIONED. FAILURE TO COMPLY WILL CORRUPT THE TRANSMITTER'S CALIBRATION.**

In the case of a transmitter saturated in the hand, the display should read +20 °C (or 20 mA if reading current).

Note: Always dry the output level down below 20 °C before wetting back up to exactly 20 °C.

If a known dewpoint is applied, then this value should be displayed.

4.3 Completing the AutoCal

Once the desired value is reached and the AutoCal process is complete, remove the screwdriver from the potentiometer and replace the weatherproof guard, fasten using the large silver coloured screw. If using the saturated transmitter method, the transmitter can be put down on a work bench.

The SDT-Ex transmitter will now output the corrected dewpoint and can be reinserted into the process.

4.4 Faults/Errors

- If the sensor is short-circuited, the transmitter will produce a constant 20.75 mA output.
- If the sensor is open-circuited, the transmitter will produce a constant 20.50 mA output.

5.0 Guarantee

All SHAW products are guaranteed for two years from the date of purchase, some exclusions are as follows:

- Removing protective guard from any sensor
- Subjecting sensor to shock or black list gases e.g. caustic and acidic gases like ammonia and chlorine
- Tampering with any internal electronics and applying incorrect supply voltage to meters
- Subjecting to excessive flow rate and contaminants
- General misuse

If you suspect a fault which you feel needs attending to under guarantee, please contact us for assistance, hopefully to help fault find and effect a remedy and if this is not successful to give precise instructions for the return for inspection.

Please note: no equipment will be replaced or repaired without having been returned for inspection either to ourselves or an authorised distributor.

6.0 Basic Definitions

Water Vapour Pressure

The pressure exerted by the water vapour contained in any mixture of gases. The total pressure exerted by the gas mixture is the sum of the pressures exerted by its components - including the water vapour. Water vapour pressure varies in direct proportion to the total gas.

Relative Humidity

The ratio of the actual water vapour pressure in the gas to the saturation water vapour pressure at the same temperature.

Dewpoint Temperature

The temperature to which the gas must be cooled in order that it should be saturated with water vapour (i.e. 100% relative humidity). For practical reasons it is referred to water above 0 °C (+32 °F) and ice below 0 °C (+32 °F). Dewpoint is expressed in degrees Celsius (°C) or degrees Fahrenheit (°F).

Parts Per Million by Volume



The ratio of the water vapour pressure to the total gas pressure, expressed as ppm(V) or vpm.

Parts Per Million by Weight

The figure is modified according to the ratio of the molecular weight of water vapour to the molecular weight of the carrier gas mixture, expressed as ppm(w).

7.0 SDT-Ex Specification

DEWPOINT SENSOR

Sensing Element:	SHAW Ultra High Capacitance Aluminium Oxide Sensor	
Sensor Type (r):	Range Dewpoint = 0.1 °C/0.2 °F resolution	
ZD:	-100 °C to +20 °C (-148 °F to +68 °F) dewpoint	
HD:	-65 °C to +20 °C (-85 °F to +68 °F) dewpoint	
P (Purple):	-100 °C to 0 °C (-148 °F to +32 °F) dewpoint	0 - 6,000 ppm(V) (AutoCal)
S (Silver):	-100 °C to -20 °C (-148 °F to -4 °F) dewpoint	0 - 1,000 ppm(V) (AutoCal)
G (Grey):	-80 °C to 0 °C (-112 °F to +32 °F) dewpoint	0 - 6,000 ppm(V) (AutoCal)
R (Red):	-80 °C to -20 °C (-112 °F to -4 °F) dewpoint	0 - 1,000 ppm(V) (AutoCal)
B (Blue):	-80 °C to +20 °C (-112 °F to +68 °F) dewpoint	0 - 23,000 ppm(V) (ManualCal)
MP:	0.1 to 100.0 ppm(V)	0.1 ppm resolution
LP:	0.01 to 10.00 ppm(V)	0.01 ppm resolution
GH:	0.01 to 10.00 g/m ³	0.01 g/m ³ resolution
LB:	0.1 to 100.0 lb/MMSCF	0.1 lb/MMSCF resolution
Intrinsic Safety Certification:	 ATEX: II 1 GD Ex ia IIC T4 Ga Approvals  0598  1180 IECEx: II 1 GD Ex ia IIIC T ₂₀₀ 135°C Da	
AutoCal:	Field calibration (span check) facility	
Factory Calibration:	Supplied with Certificate of Calibration traceable to the National Physical Laboratory (NPL)	
Accuracy:	±2 °C (±3.6 °F) dewpoint, NPL traceable -90 °C to +20 °C (-130 °F to +68 °F)	
Temperature Coefficient:	Temperature compensated	
Resolution:	0.016 mA	
Repeatability:	Better than ±0.3 °C (±0.54 °F) dewpoint	
Operating Temperature:	-20 °C to +60 °C (-4 °F to +140 °F)	
Storage Temperature:	-20 °C to +70 °C (-4 °F to +158 °F)	
Response Times:	Wet to dry: -20 °C to -60 °C (-4 °F to -76 °F) less than 120 secs Dry to wet: -100 °C to -20 °C (-148 °F to -4 °F) less than 20 secs	
Sample Flow Rate:	Independent but ideally two to five litres per minute. Max: 25 litres per minute	
Calibration Warranty:	12 months subject to usage	

ELECTRICAL

Electromagnetic Compatibility (EMC):	Immunity: complies with EN 61000-6-1 Emissions: complies with EN 61000-6-3
Warm Up Time:	10 seconds
Fault Conditions:	Sensor open circuit: output drives to 20.50 mA Sensor short circuit: output drives to 20.75 mA
Isolation:	Sensing element connected to the 4-20 mA loop but isolated from transmitter body
Output Signal:	4-20 mA Linear
Operating Voltage:	7 V to 28 V DC reverse polarity protected
Maximum Series Resistance:	= {40 x (Supply Voltage - 7)} Ω

MECHANICAL

Operating Pressure:	From 1kPa (0.01 barA) to maximum 35,000kPa (350 barA)
Operating Humidity (External):	Maximum - 95% RH non-condensing
Cable Terminations:	IP66 (NEMA 4X) rated, size C, DIN EN 175301 connector at the transmitter and other end terminated with bootlace ferrules
Cable:	Supplied with two metres standard cable. Nominal diameter 3.4 mm, 92 ohms/km at 20 °C
Transmitter Enclosure:	316 stainless steel body with size C, DIN EN 175301 connector
Sensor Protection:	316 sintered stainless steel filter - 50 micron
Probe Material (Wetted Parts):	316 stainless steel
Weatherproof Classification:	IP66/NEMA 4X when connector mated to transmitter
Mechanical Connection:	¾" UNF (16tpi) with integral Viton "O" ring seal
Mechanical Warranty:	24 months in case of faulty workmanship and defective parts
Weight:	175 grams (includes connector)

8.0 Hygrometric Equivalents

DEWPOINT °C	DEWPOINT °F	VAPOUR PRESSURE mmHG	PARTS PER MILLION by VOLUME	DEWPOINT °C	DEWPOINT °F	VAPOUR PRESSURE mmHG	PARTS PER MILLION by VOLUME
-150	-238	7 x 10 (-15)	9.2 x 10 (-12)	-52	-62	.02305	30.329
-140	-220	3 x 10 (-10)	3.9 x 10 (-7)	-50	-58	.02961	38.961
-130	-202	7 x 10 (-9)	9.2 x 10 (-6)	-48	-54	.03786	49.816
-120	-164	9 x 10 (-8)	1.2 x 10 (-4)	-46	-51	.04819	63.408
-118	-180	.00000015	.00020	-44	-47	.06108	80.368
-116	-177	.00000025	.00033	-42	-44	.07709	101.43
-114	-173	.00000041	.00054	-40	-40	.09691	127.51
-112	-170	.00000066	.00087	-38	-36	.12133	159.64
-110	-166	.00000107	.00141	-36	-33	.15133	199.12
-108	-162	.00000169	.00222	-34	-29	.1880	247.37
-106	-159	.00000266	.00350	-32	-26	.2328	306.32
-104	-155	.00000413	.00543	-30	-22	.2871	377.76
-102	-152	.00000636	.00837	-28	-18	.3529	464.34
-100	-148	.00000968	.0127	-26	-15	.4323	568.82
-98	-144	.00001459	.0192	-24	-11	.5277	694.34
-96	-141	.00002178	.0287	-22	-8	.6422	845.00
-94	-137	.00003224	.0424	-20	-4	.7790	1025.00
-92	-134	.00004729	.0622	-18	0	.9421	1239.61
-90	-130	.00006879	.0905	-16	+3	1.136	1494.74
-88	-126	.00009924	.1305	-14	+7	1.365	1796.05
-86	-123	.00014205	.1869	-12	+10	1.636	2152.63
-84	-119	.0002018	.2655	-10	+14	1.956	2573.68
-82	-116	.0002844	.3742	-8	+18	2.331	3067.11
-80	-112	.0003981	.5238	-6	+21	2.771	3646.05
-78	-108	.0005533	.7208	-4	+25	3.285	4322.37
-76	-105	.0007638	1.005	-2	+28	3.884	5110.53
-74	-101	.0010476	1.378	0	+32	4.581	6027.63
-72	-98	.0014275	1.878	+2	+36	5.292	6963.16
-70	-94	.001933	2.543	+4	+39	6.099	8025.00
-68	-90	.002603	3.425	+6	+43	7.012	9226.32
-66	-87	.003483	4.583	+8	+46	8.045	10585.53
-64	-83	.004635	6.099	+10	+50	9.209	12117.10
-62	-80	.006135	8.072	+12	+54	10.518	13839.47
-60	-76	.008076	10.626	+14	+57	11.988	15773.68
-58	-72	.010576	13.916	+16	+61	13.635	17940.79
-56	-69	.013780	18.132	+18	+64	15.478	20365.79
-54	-65	.01787	23.513	+20	+68	17.535	23072.37

9.0 Appendix

9.1 Appendix A - SDT-Ex and PR5104BB2A Signal Isolator Connection

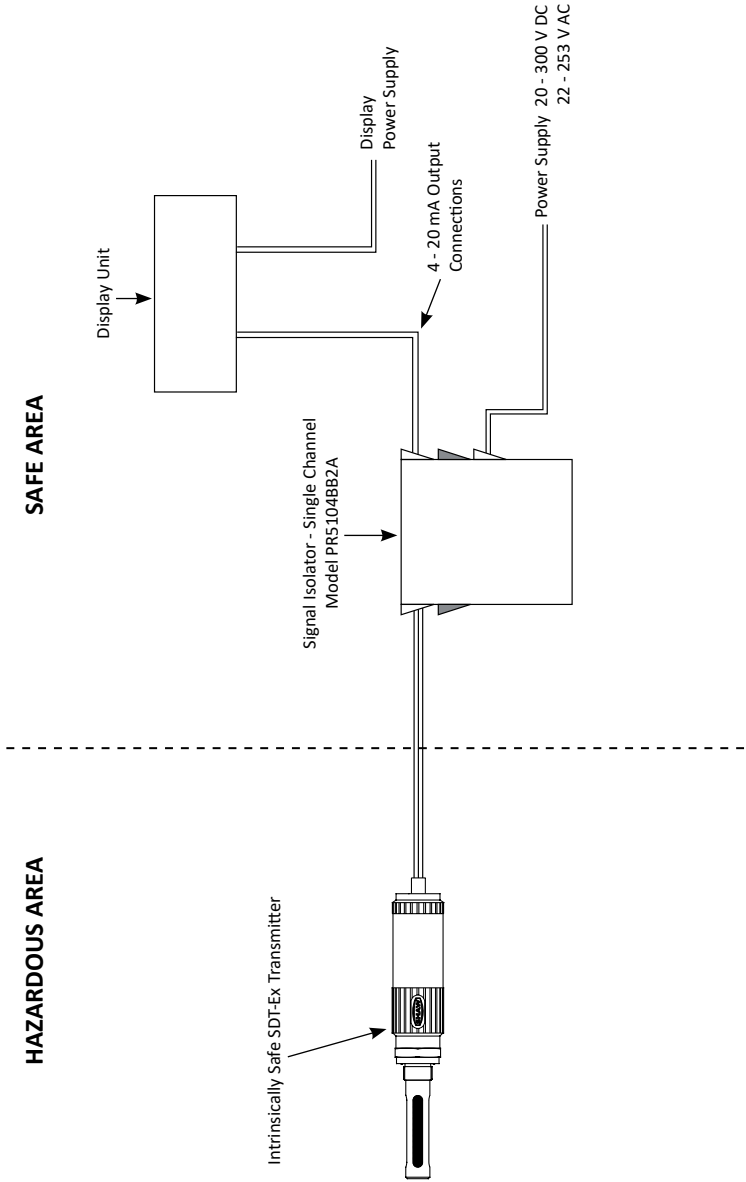

9.2 Appendix B - PR5104BB2A to SDT-Ex Connections

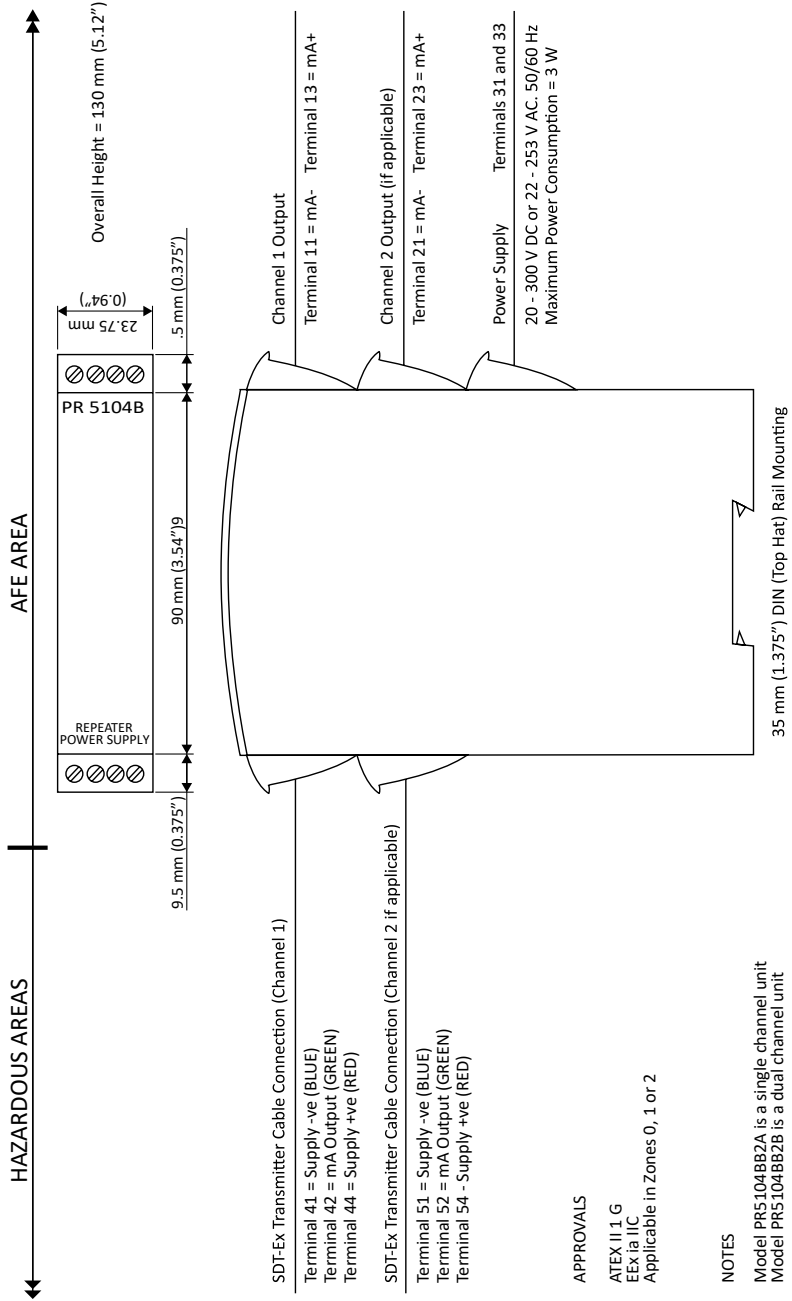

9.3 Appendix C - SDT-Ex with Connector, General Arrangement

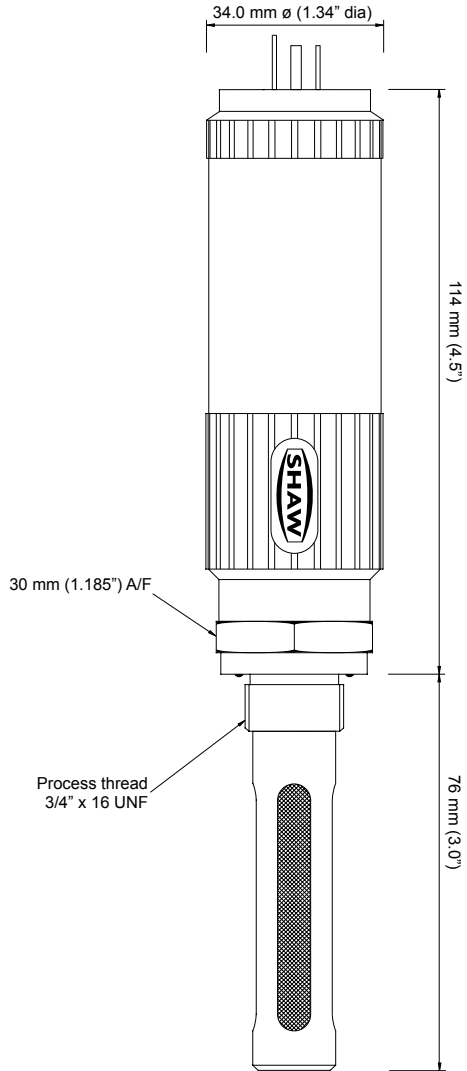

9.4 Appendix D - Transmitter Holder General Arrangement

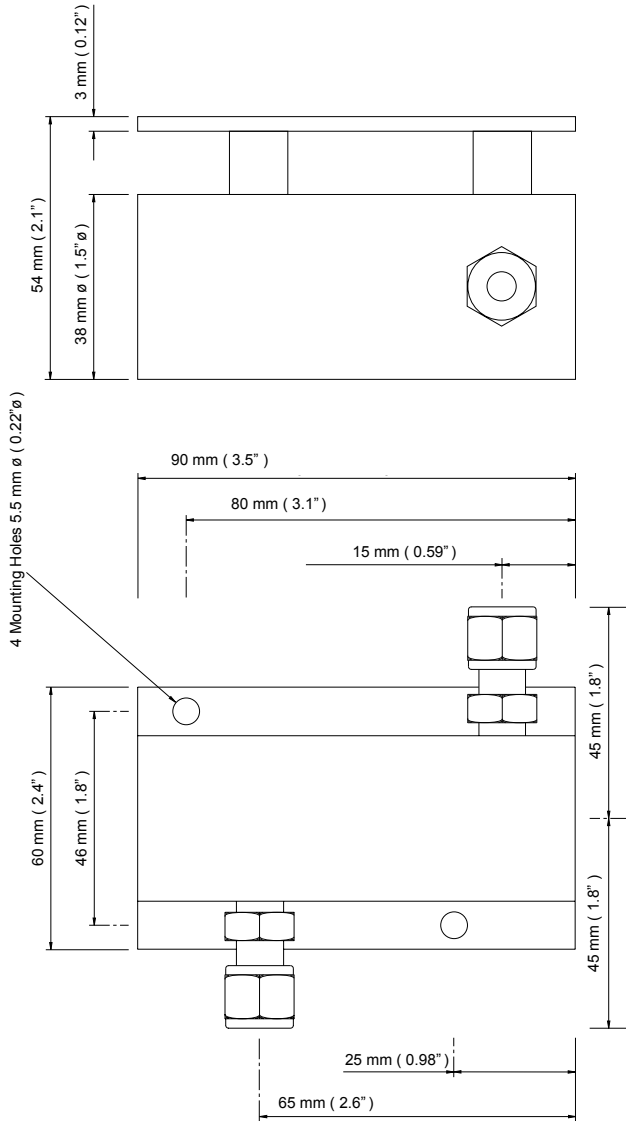

NOTE:
 The assembly is shown with 0.25" OD tube fittings.
 The dimension across the tube fittings will vary for all other size fittings.

