

SU2

Sample System

The Shaw Moisture Meters SU2 sample system is designed to provide ideal sampling conditions for dewpoint measurement.

Manufactured in the UK by Shaw Moisture Meters, this unit is a very simple and effective conditioning panel which ensures that the sample pressure and flow is suitable for dewpoint measurement.

Simple to setup and install, the SU2 sample system comprises: a stainless steel pressure regulator and flow meter, mounted on a powder coated back plate. The SU2 is a popular choice throughout the world, where a simple solution for dewpoint sampling is required.



Features

- Designed for gas or general compressed air sampling
- Reduce inlet pressure from up to 210 bar (3,045 psi)
- Adjustable sample flow of up to 10 litres per minute
- Stainless steel fittings and pipework
- Inlet and outlet fittings with a choice of 1/8", 1/4" or 6 mm compression fittings
- Sampling options: Input pressure (pr): Up to 200 bar
- Mounted on the top of the instrument with 2 x 5 mm mounting holes
- Overall dimensions: 106 mm (h) x 160 mm (w) x 110 mm (d)
- Approximate weight: 1.6 kg



PLEASE NOTE:
The SADP dewpoint meter is **not** included.

Ordering Information

- SU2 - (1/8", 1/4" or 6 mm fittings) for 200 bar variant
Please state required fittings with order.

Sample Systems Overview

Shaw Moisture Meters sample systems are engineered solutions for extracting and analysing a representative sample of the process air or gas, which is then either vented off to atmosphere or returned back to the process.

This range of sample systems has been developed through over 60 years of experience in industrial moisture analysis and all systems are built using the highest quality components to ensure long term performance and reliability in even the toughest of applications.

Our standard range of sample systems can be seen at www.shawmeters.com. However, if your particular requirements are not met by any of those shown, please contact us and our engineers will be happy to advise and custom design a system for your specific application.

SU2 Assembly Diagram

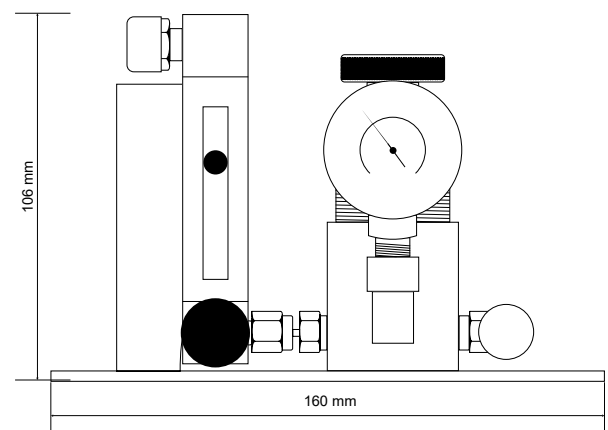

SU2_Iss1.4